

SERVICE REQUIREMENTS

- Ⓔ 115 VAC, 30 AMP, GROUNDED, SINGLE PHASE POWER
- Ⓕ 2" MNPT DISCHARGE TO SEWER CONNECTION
- Ⓖ 2" FNPT INFLUENT WATER CONNECTION
- ⓪ 2" FNPT TREATMENT TANK OVERFLOW CONNECTION

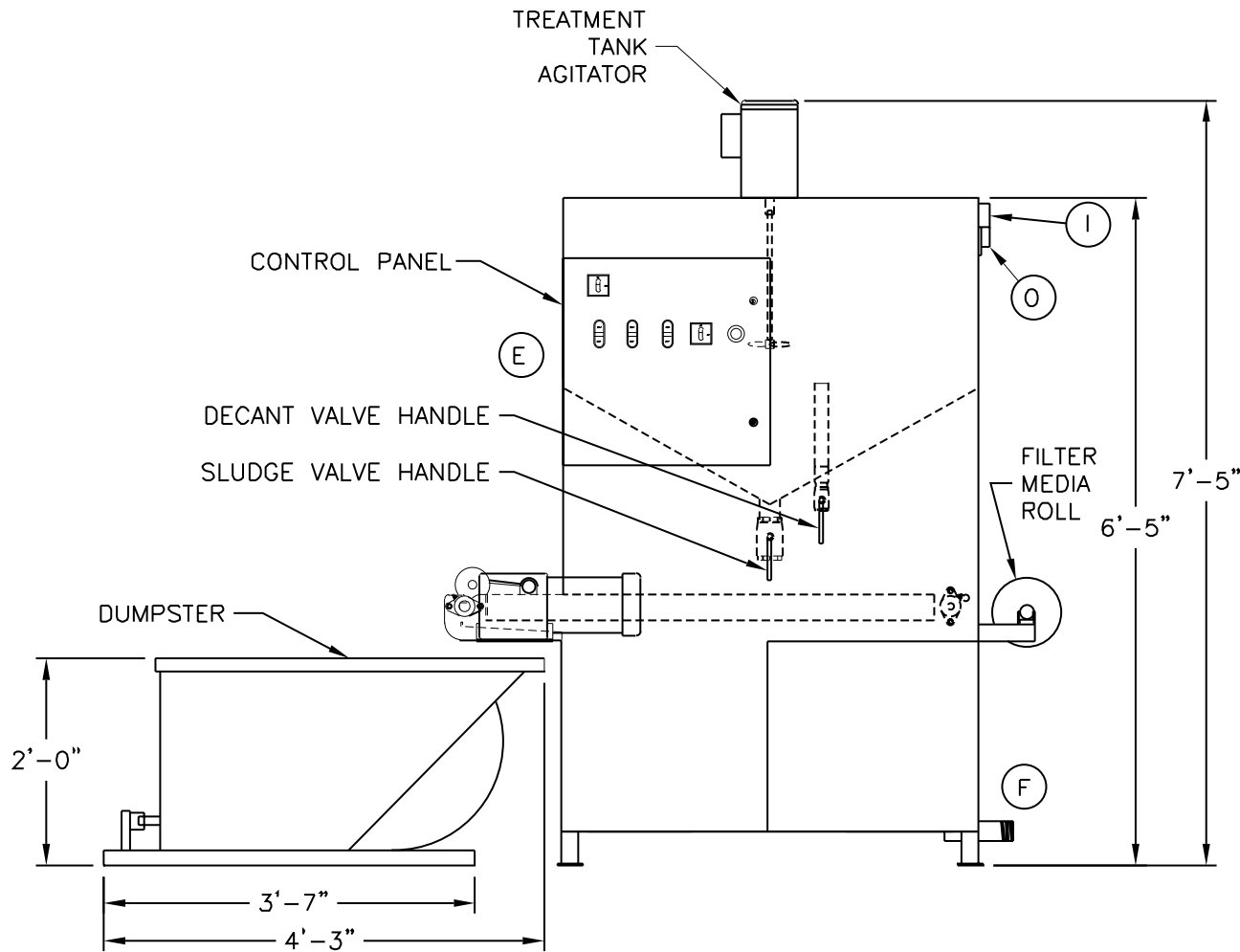

TT-200
ELEVATION DRAWING