

SERVICE REQUIREMENTS

- (E) 480 VAC, 15 AMP, GROUNDED, 3 PHASE POWER TERMINATED AT THE DISCONNECT IN THE CONTROL PANEL.
- (A) ½" FNPT AIR SUPPLY CONNECTION. 80-100 PSI, CLEAN, DRY, AIR REQUIRED, WITH LOCKING HANDLE VALVE ON SERVICE LINE.
- (I) 2" FNPT INFLUENT WATER INLET CONNECTION.
- (F) 2" MNPT EFFLUENT WATER DISCHARGE CONNECTION.

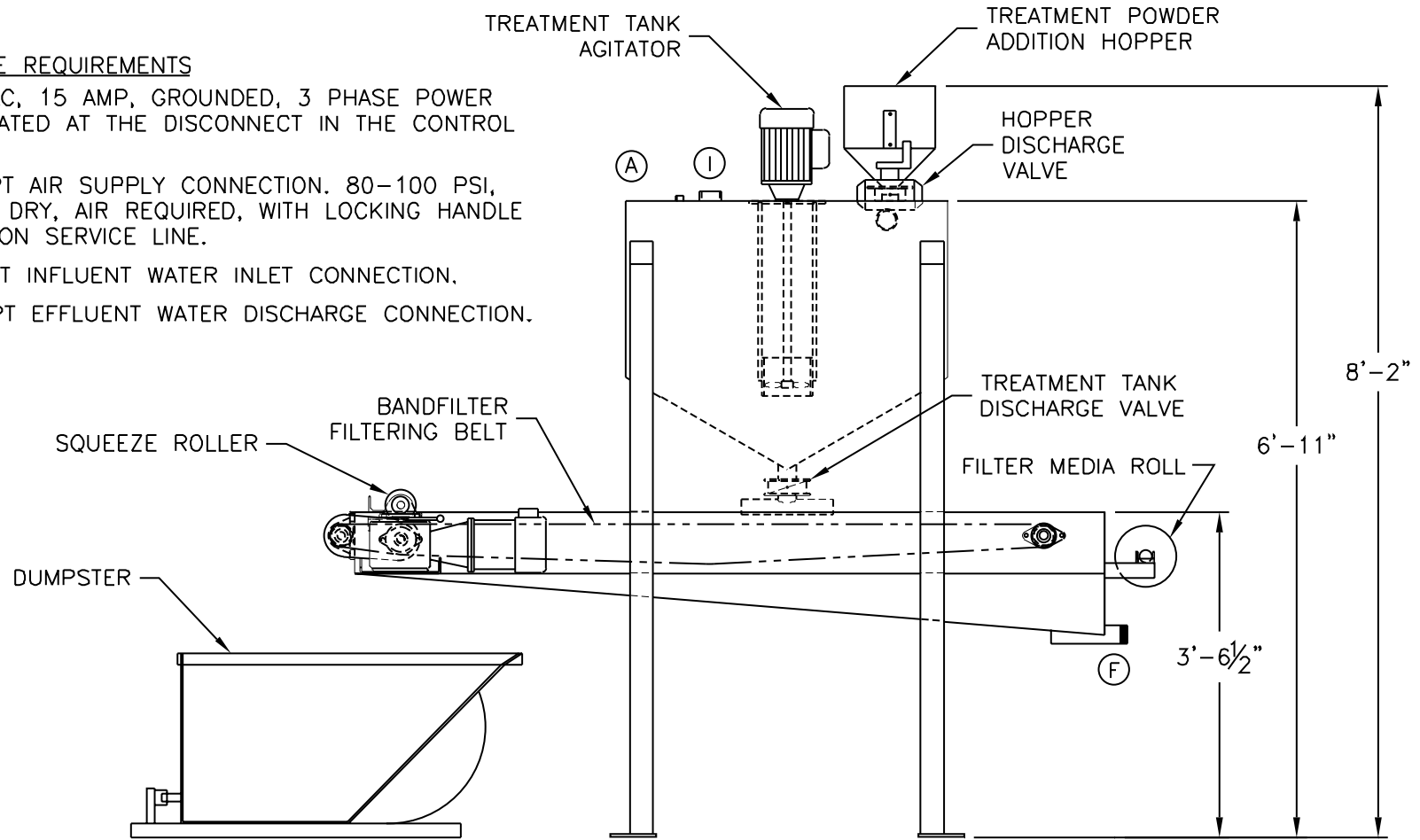

NOTE:  
CONTROL PANEL & ACCESS  
LADDER NOT SHOWN FOR CLARITY.

# 200 SA

ELEVATION DRAWING